

WUZ 100

Operating instructions

Contents:

Page

Declaration of conformity	3
1. General aspects	4
1.1 Affiliation	4
1.2 Inquiries and purchase orders	4
1.3 Technical data	4
1.4 Field of application	5
1.5 Accessories	5
2. Safety	5
2.1 Labelling of instructions in the operating instructions	6
2.2 Qualification and training of staff	6
2.3 Hazards caused by non-observation of safety instructions	6
2.4 Safety-conscious work	7
2.5 Safety instructions for user / operator	7
2.6 Safety instructions for maintenance, inspection and installation work	7
2.7 Unauthorised modification and spare parts production	7
2.8 Impermissible operating modes	7
3. Transport and intermediate warehousing	8
3.1 Transport	8
3.2 Intermediate warehousing / conservation	8
4. Description	8
4.1 General aspects	8
4.2 Design and functionality	8
5. Installation	8
5.1 Preparation	8
5.2 Installation	9
5.2.1 Setting up	9
5.2.2 Inlet	9
5.2.3 Pressure line	9
5.2.4 Ventilation	9
5.2.5 Electrical connection	9
6. Commissioning	10
7. Maintenance / servicing	10
7.1 Inspection and maintenance intervals	10
7.2 Maintenance work	11
7.2.1 Collecting tank	11
7.2.2 Check valve	11
7.2.3 Miscellaneous	11
8. Malfunctions; causes and troubleshooting	11
9. Warranty	12
10. Technical changes	12
Annex: A Assembly example	12
B Dimensions	13
C Sectional drawing and spare parts list	14

Declaration of conformity

Herewith we

**ZEHNDER Pumpen GmbH
Zwönitzer Straße 19
D-08344 Grünhain-Beierfeld,**

declare that the sewage lifting units of series **WUZ 100**

comply with the relevant regulations as follows:

- **EC Low Voltage Directive 2014/35/EU**
- **Electromagnetic Compatibility Directive 2014 / 30 / EU**
- **EC Machinery Directive 2006/42/EG**

Applied harmonised standards, particularly

Applied national technical standards and specifications, particularly

EN 60335-1:2012/A11:2014

EN 60335-2-41:2003/A2:2010

EN 809:1998/AC:2010

EN 55014-1:2006/A2:2011, EN 55014-2:1997/A2:2008

EN 61000-3-2:2014, EN 61000-3-3:2013

EN 61000-6-1:2007, EN 61000-6-2:2005, EN 61000-6-3/A1:2011, EN 61000-6-4/A1:2011

EN 12050-1

Grünhain, 22th December 2016

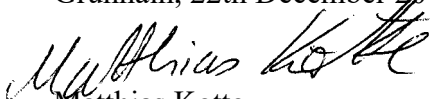

Matthias Kotte

Product Development

1. General aspects

1.1 Affiliation

These operating instructions are valid for the sewage lifting units of the WUZ 100 series.

In case of non-observation to the operating instructions - in particular the safety instructions - as well as unauthorised modification of the device or the installation of non-original spare parts the warranty claims will automatically become void. The manufacturer assumes no liability for any damage resulting from this!

As any other electrical appliance, this product can also fail due to missing main power or a technical defect. If a damage can occur as a result, an emergency power generator, a manual membrane pump, a second system (double system) and/or a mains-independent alarm system should be planned according to the application. We as manufacturers will be happy to advise you also after the purchase. In case of defects or damages, please get in touch with your dealer.

Manufacturer: Zehnder Pumpen GmbH
Zwönitzer Straße 19
D-08344 Grünhain-Beierfeld

Construction sizes: WUZ 100 3.0 WUZ 100 3.0 double
WUZ 100 4.0 WUZ 100 4.0 double
WUZ 100 5.5 WUZ 100 5.5 double
WUZ 100 7.5 WUZ 100 7.5 double

Status of the operating instructions: May 2008

1.2 Inquiries and purchase orders

Please send your inquiries and orders to your specialist dealer.

1.3 Technical data

Single systems:

Type	Input power P ₁ [kW]	Nominal power P ₂ [kW]	Voltage U [V]	Rated current I _{max} [A]	Speed (50 Hz) min ⁻¹	Feed volume [m ³ /h]	Pumping head [m]	Pressure connection
WUZ 100 3.0	4.0	3.0	400	6.9	1400	130	10	DN 100
WUZ 100 4.0	5.5	4.0	400	11.2	1400	140	13	DN 100
WUZ 100 5.5	6.3	5.5	400	12.1	1400	160	18	DN 100
WUZ 100 7.5	8.7	7.5	400	16.9	1400	165	22	DN 100

Type	Gross volume [l]	Switching volume [l]	Inlet connection	Free passage [mm]	Weight [kg]	Dimensions [mm]	Minimum space requirement [m]
WUZ 100 3.0	480	270	DN 150	80	210	Ø 1000	2 x 1.5
WUZ 100 4.0	480	270	DN 150	80	220	Ø 1000	2 x 1.5
WUZ 100 5.5	480	270	DN 150	100	225	Ø 1000	2 x 1.5
WUZ 100 7.5	480	270	DN 150	100	240	Ø 1000	2 x 1.5

Maximum media temperature: 55 °C

Double systems:

Type	Input power P ₁ [kW]	Nominal power P ₂ [kW]	Voltage U [V]	Rated current I _{max} [A]	Speed (50 Hz) min ⁻¹	Feed volume [m ³ /h]	Pumping head [m]	Pressure connection
WUZ 100 double 3.0	4.0	3.0	400	6.9	1400	120	10	DN 100
WUZ 100 double 4.0	5.5	4.0	400	11.2	1400	140	13	DN 100
WUZ 100 double 5.5	6.3	5.5	400	12.1	1400	160	18	DN 100
WUZ 100 double 7.5	8.7	7.5	400	16.9	1400	165	22	DN 100

Type	Gross Volume [l]	Switching volume [l]	Inlet connection	Free passage [mm]	Weight [kg]	Dimensions [mm]	Minimum space requirement [m]
WUZ 100 double 3.0	1000	500	DN 150	80	370	1450x950	2.5 x 1.5
WUZ 100 double 4.0	1000	500	DN 150	80	385	1450x950	2.5 x 1.5
WUZ 100 double 5.5	1000	500	DN 150	100	400	1450x950	2.5 x 1.5
WUZ 100 double 7.5	1000	500	DN 150	100	425	1450x950	2.5 x 1.5

Maximum media temperature: 55 °C

Materials

Tank.....	PE HD	
Seal carrier.....	Cast iron	
Impeller.....	Cast iron	
Screws.....	Steel, galvanized	
Pump housing.....	Cast iron	
Shaft sealing.....	Motor-side	Shaft seal
	Pump-side	up to 4 kW mechanical seal, from 5.5 chilled casting seal
Sealing materials.....	NBR	
Impeller nut.....	Stainless steel	

1.4 Field of application

The sewage lifting units of the series WUZ 100 serve to dispose of (collecting and conveying) domestic and industrial dirt water and wastewater, which occur below the sewer backwater level.

Double systems are used everywhere, where an interruption of the sewage disposal must not occur according to DIN 1986.

The sewage lifting units of the series WUZ 100 must not be used to convey waste waters containing substances which attack or damage the materials of the pump or of the collecting tank.

Operating Limits

- **The lifting unit is not designed for continuous operation! The conveying data stated on the factory plate apply only for intermittent periodic duty (S3 25 %).**
- **The maximum permissible feed flow must always be smaller than the feed volume of a pump (see type plate)**

1.5 Accessories

The sewage lifting units of series WUZ 100 are delivered with:

- Level control and switch box

2. Safety:

(from: "VDMA standard sheet 24 292")

These operating instructions contain basic instructions which have to be observed during set-up, operation and maintenance. For this reason, these operating instructions must by all means be read before installation and commissioning by the installation technician as well as by the competent specialist staff / user, and must be permanently available at the location of the device.

Not only the general safety instructions mentioned in this main point on safety have to be observed, but also the special safety instructions mentioned in the other main points, for example for private use.

2.1 Labelling of instructions in the operating instructions

The safety instructions mentioned in these operating instructions, which may cause hazards for persons in case of non-observation, have been marked by the general danger symbol



Safety sign according to DIN 4844 - W 9,

in case of warning against electrical voltage with



Safety sign according to DIN 4844 - W 8

especially marked.

In case of safety instructions, the non-observation of which may cause hazards for the machine and its functions, the word **ATTENTION** is added.

Instructions attached directly to the machine, such as

- Rotation arrow
- Marks for fluid connections

must be definitely observed and kept in fully legible condition.

2.2 Qualification and training of staff

The staff for operation, maintenance, inspection and installation must have the corresponding qualification for this work. For this reason, the area of responsibility, the competency and the supervision of the staff has to be precisely defined by the company. If the staff does not have the necessary knowledge, the said has to be trained and instructed. If and when necessary, this may be carried out by the manufacturer / supplier of the pump on behalf of the pump operator. Moreover, the operator has to ensure that the content of the operating instructions is understood completely by the staff.

2.3 Hazards caused by non-observation of safety instructions

The non-observation of the safety instructions may endanger persons as well as the environment, and may have consequences for the environment and machine. The non-observation of the safety instructions will result in the loss of all claims for damages.

In detail, the non-observation may cause the following hazards, for example:

- Malfunction of important functions of the machine / plant
- Malfunction of the mandatory methods of maintenance and repair
- Danger to persons caused by electrical, mechanical and chemical effects
- Danger to the environment caused by leakage of dangerous substances

2.4 Safety-conscious work

The safety instructions mentioned in these operating instructions, the existing national regulations on accident prevention as well as potential in-company work, operating and safety instructions of the user must be observed.

2.5 Safety instructions for user / operator

- If hot or cold machine parts could lead to hazards, these parts have to be protected against touch by the user.
- Touch protection for moving parts (e.g. coupling) must not be removed from the machine being in operation.
- Leakage (of the shaft seal, for example) of hazardous material conveyed (e.g. explosive, toxic, hot) must be removed in such a way that no danger is caused to persons and the environment. Legal regulations have to be observed.
- Hazards caused by electric energy must be excluded (for details here, please refer to the country-specific regulations and the regulations of the local energy supply companies).

2.6 Safety instructions for maintenance, inspection and installation work

The user has to make sure that all maintenance, inspection and installation work is carried out by authorised and qualified specialist personnel only, who has sufficiently been informed by studying the operating instructions.

Basically, work on the machine may be carried out only at standstill. The procedure to shut down the machine described in the operating instructions must be observed by all means.

Pumps or pump assemblies, which convey media hazardous to health, must be decontaminated. Immediately after completing the work, all safety and protection devices have to be fitted again and/or have to be made functional again.

Before recommissioning, the points listed in the chapter on initial commissioning have to be observed.

2.7 Unauthorised modification and spare parts production

Modifications or changes to the machine shall be permissible only after consultation with the manufacturer. Original spare parts and accessories authorised by the manufacturer serve to ensure safety. The use of other parts may result in the loss of liability for the consequences that may occur.

2.8 Impermissible operating modes

The operational safety of the machine supplied is ensured only when used as intended according to Section 1 - General - of the operating instructions. The threshold values indicated in the data sheet must by no means be exceeded.

3. Transport and intermediate warehousing

3.1 Transport

The sewage lifting units of the series WUZ 100 must not be thrown or dropped. Moreover, they shall be kept horizontally during transport.

3.2 Intermediate warehousing / conservation

For intermediate warehousing and conservation, it is sufficient to store the plant at a cool, dark, dry and frost-proof place. The units should stand horizontally.

4. Description

4.1 General aspects

The sewage lifting units of the series WUZ 100 are ready-to-plug, fully flood-proof single or double systems with gas and odour-proof plastic collecting tank. They operated with vertical waste water pumps without blockage and automatic level control. They are equipped completely with switch box and all necessary switching elements.

4.2 Design and functionality

Due to an inlet DN 150 (flange connection), the waste water (natural gradient) flows into the collecting tank of the sewage lifting unit WUZ 100.

The collecting tank is designed for **pressureless operation**, that is the occurring waste water is buffered without pressure and then conveyed into the sewage channel.

In the pitot tube that is screwed on the upper side of the tank, the water rises and keeps compressing the air being in the pitot tube so long until the pressure operates the pitot tube switch in the switch box. As a result, the pump is switched on and conveys the water from the tank via the pressure line into the higher channel. With the lifting unit WU 100 Double, the switch box contains a toggle switch which causes the pumps to turn on alternately. Only in overload operation (one pump cannot managed the inflowing amount of water), the second pump will turn on the second pump.

A check valve in the pressure line (to be provided acc. to DIN 19 760) prevents the water from flowing back out of the pressure line into the tank.

The units are equipped with a potential-free contacts to which alarm equipment (bell, horn, buzzer et cetera) can be connected.

In the switch box, a motor protection relay is located upstream the motor which automatically switches off the motor in case of overload (too high power consumption).

5. Installation

5.1 Preparations

- Trouble-free operation of the lifting unit depends not least on a correct and impeccable assembly. For this reason, the following points must be observed:
- The installation location should be a well-ventilated, dry and frost-free room.
- The installation site must be amply dimensioned. The room height should be approx. 2 to 2.5 m. According to DIN 1986, Part 3, the following applies: *“All plant components... (and)... all operating elements... must be safely accessible at any time and possible to be operated without any problems. ...These plant components must not be obstructed by stored goods, furniture, coverings or similar things...”*

- The foundation of the installation room must be designed to meet potentially occurring loads depending on the size of the plant.
- In rooms which often lie lower, ground water or seepage water often accumulates. That is why in one corner of the room, there should be a small shaft, where these liquids accumulate and can be disposed of using a cellar drainage pump.
- A ceiling hook above the installation site of the lifting unit facilitates the assembly as well as potential maintenance and repair work on the pump.
- Before starting installation, all structural and line measurements should be checked and compared with the dimensions of the unit. While doing so, it has to be particularly made sure that the constantly declining inlet line does not lie lower than the inlet height of the collecting tank.

5.2 Installation

During installation, it is absolutely necessary to ensure a stress-free and tight installation of the pipelines and fittings.

5.2.1 Setting up

The sewage lifting units of the series WUZ 100 are aligned at the installation site according to potentially existing pipelines. Here, they are set up exactly horizontal.

The sewage lifting unit has to be secured by means of suitable attachment equipment on site against twisting and buoyant floating!

5.2.2 Inlet

The inlet line is connected to the flange DN 150. It must always be installed on a downhill incline. Uphill sections in the inlet are not permitted.

5.2.3 Pressure line

Installation of a check valve in the pressure line of the lifting unit is absolutely required:

DIN 19 760, Part 3: *“Following interruption of the pump delivery, a backflow preventer must automatically impede the backflow of the waste water from the pressure line. When the pump starts delivering, the backflow preventer must automatically open...”*

It is recommended to install a shut-off valve behind the check valve in order to facilitate cleaning or potential replacement of the check valve.

The pressure line must be installed constantly rising and without unnecessary leaps in an arc beyond the flood level and then constantly descending toward the sewer connections. Pipelines and fittings must, where necessary, be supported using pipe clamps or brackets.

5.2.4 Ventilation

The tank ventilation (flange DN 100) is installed either directly to the venting line of the building or guided separately above the roof.

5.2.5 Electrical connection

Safety precautions

- All electrical systems used must comply with the standard IEC 364 / VDE 0100, that is sockets, for example, must have earth terminals.
- The electrical connection may be carried out by an electrically qualified person! The pertinent VDE regulation 0100 must be observed!

- **The electrical network, to which the plant is connected, must have been fitted with a highly sensitive FI protected switch IA <30 mA before the control, or to prevent a failure of the control when the FI protected switch trips, one FI protected switch per pump has to be installed between the control and pump. For installations in bathrooms and showers, the corresponding regulations of DIN VDE 0100 Part 701 have to be observed.**
- **Please observe the regulations of EN 12 056-4.**
- **For AC power connection, external protection has to be carried out with circuit breakers of characteristic K, generally 3-pole mechanically locked. In this way, complete supply isolation is ensured and 2-phase run excluded.**
- **In dry rooms, all electrical devices such as controls, alarm transmitters and sockets must be installed flood-proof.**
- **Attention! Before every installation and disassembly of the pump or other work on the plant, it must be disconnected from the mains supply.**
- **The motor can overheat due to overload. In case of overheating, never touch the hot surfaces on the motor.**
- **When using an extension cable, it must meet the quality of the supplied connecting cable.**

The switchbox is fastened to the wall, and the electrical connecting cables are connected according to the circuit diagram. While doing so, it has to be seen to it that the electrical system complies with the applicable VDE guidelines.

The circuit diagram for the wiring of the lifting unit is in the switchbox and should be left there in order to facilitate the work of the maintenance and customer service personnel.

6. Commissioning

Before commissioning, all connections should be checked again for correct installation. The shut-off valve must be open.

Now the plug is put into the socket and the pump's direction of rotation checked. This is done by briefly setting the manual/0/automatic switch to "Manual". When the motor comes to a standstill, the direction of rotation can be compared with the correct direction of rotation (rotation arrow) on the top surface at the sight glass. If the pump rotates the wrong way round, two of the three phases will have to be interchanged.



Prior to any works on the electrical system, pull the power plug!

Now the manual/0/automatic switch is set to "Automatic" and a test run is carried out. For this purpose, the collecting tank is filled via the normal inlet (washbasin, toilet et cetera). The plant must automatically switch on, pump the tank empty and switch off again. After switching off, no water may flow from the pressure line back into the tank, and the pitot tube in the tank must have fully emerged out of the water. If this is not the case, the run-on time will have to be extended.

During the test run all lines and fitting are checked again for tightness and newly caulked.

If the lifting unit works properly, the switch will keep being in "Automatic" position.

7. Maintenance / servicing

7.1 Inspection and maintenance intervals

Inspection and maintenance intervals according to DIN 1986, Part 31: "*Sewage lifting units shall be checked once a month by the operator by observing a switching cycle for operability and tightness. ...The unit shall be maintained by a specialist. The time intervals shall not be longer than*

1. *quarter of a year with units in commercial operations*
2. *half a year with units in apartment blocks*
3. *one year with units in detached houses*

7.2 Maintenance work



Prior to any works on the unit, pull the power plug!

7.2.1 Collecting tank

Open the inspection cover and flush the tank by means of using a hose in order to loosen dirt deposits on the tank walls.

7.2.2 Check valve

Open the inspection cover and clean the interior of the check valve.

7.2.3 Miscellaneous

All further maintenance works must be carried out by customer service.

8. Malfunctions; causes and troubleshooting



Prior to any works on the unit, pull the power plug!

ATTENTION To dismantle the motor unit from the tank, the 4 hexagon screws (Item 16 of the spare parts list) **must not** be loosened, because otherwise the mechanical seal is destroyed, oil escapes and the warranty will become void! If only the motor unit shall be dismantled, all 4 screws (Item 13 of the spare parts list) have to be loosened. If the complete pump shall be dismantled from the tank, all 4 nuts (item 23 of the spare parts list) must be loosened.

Malfunction	Cause	Troubleshooting
1. Motor does not rotate	<ul style="list-style-type: none"> - Too low voltage, voltage missing - Incorrect power connection - Power cable defective - Impeller blocked - Motor protection switched off due to overheating, Blockage, voltage error - Controlling error - Motor defective 	<ul style="list-style-type: none"> - Check voltage supply - Correction - Replacement / customer service - Clean - Check / customer service - Check / customer service - Replacement / customer service
2. Motor rotates, but does not convey	<ul style="list-style-type: none"> - Impeller clogged or worn - Check valve clogged - Shut-off valve clogged or closed - Pressure line clogged - Intake socket clogged - Direction of rotation incorrect - Water shortage in the tank - Tank ventilation clogged - Pump housing ventilation clogged 	<ul style="list-style-type: none"> - Clean / replace - Clean - Clean / open - Clean - Clean - Correction - Switch off / customer service - Clean - Clean
3. Motor rotates, but switches off	<ul style="list-style-type: none"> - Voltage wrong or fluctuates - Thermal protection incorrectly designed - Power consumption too high 	<ul style="list-style-type: none"> - Correction / customer service - Check / customer service - Customer service
4. Motor does not switch off	<ul style="list-style-type: none"> - Controlling error - Pitot tube clogged 	<ul style="list-style-type: none"> - Customer service - Check / clean

9. Warranty

As manufacturer, we provide for this device a warranty of 24 months from the date of purchase.

The sales receipt is considered proof regarding the warranty. Within this warranty period, we will at our discretion, either by means of repair or replacement, correct free of charge all defects due to material or manufacturing defects of the unit.

The warranty excludes all damage attributable to improper use or wear and tear. We do not assume any liability for consequential damages which occur due to a failure of the device.

10. Technical changes

We reserve the right to make technical changes in terms of progress.

Annex A: Assembly example

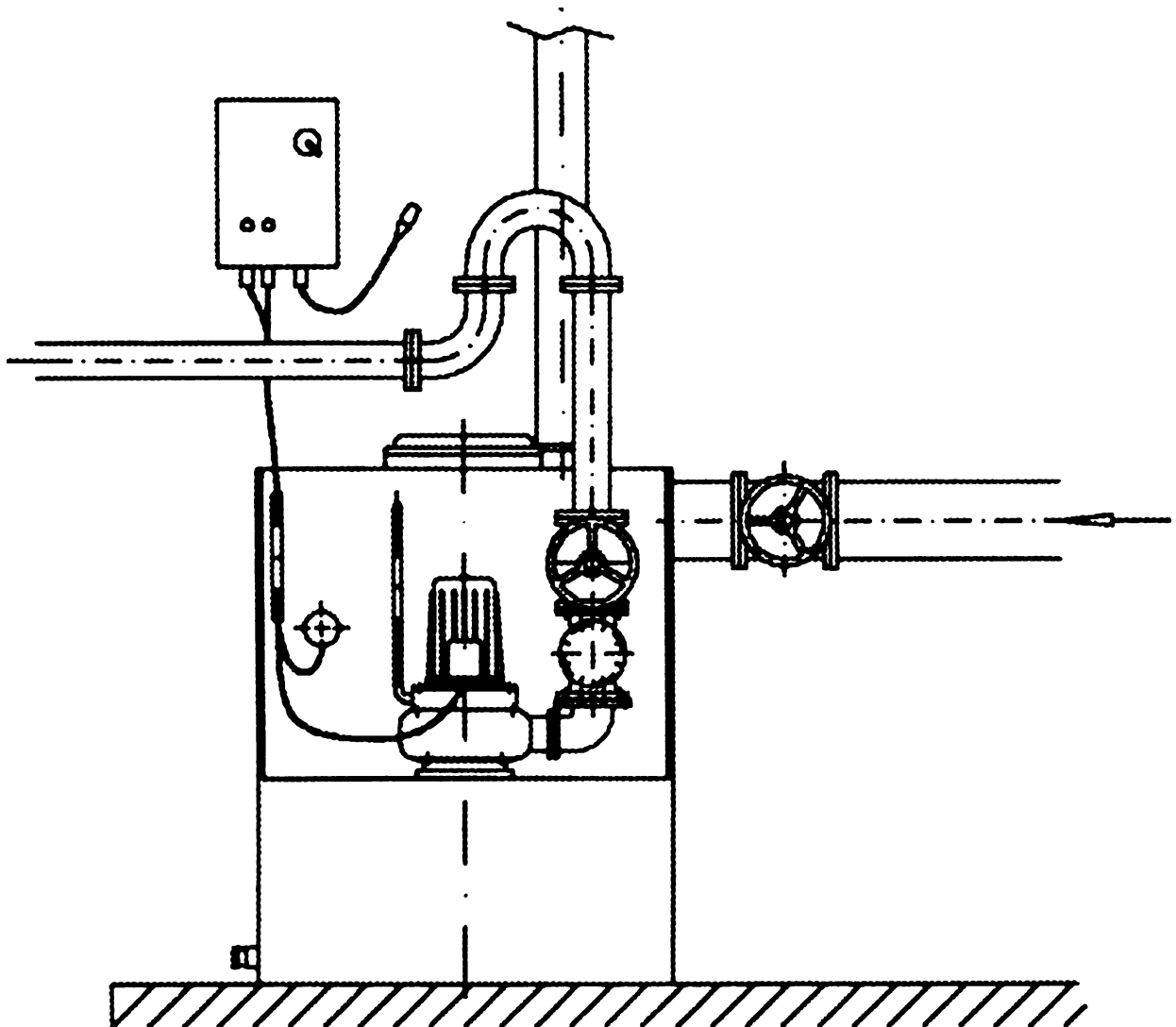

Annex B: Dimensions

WUZ 100

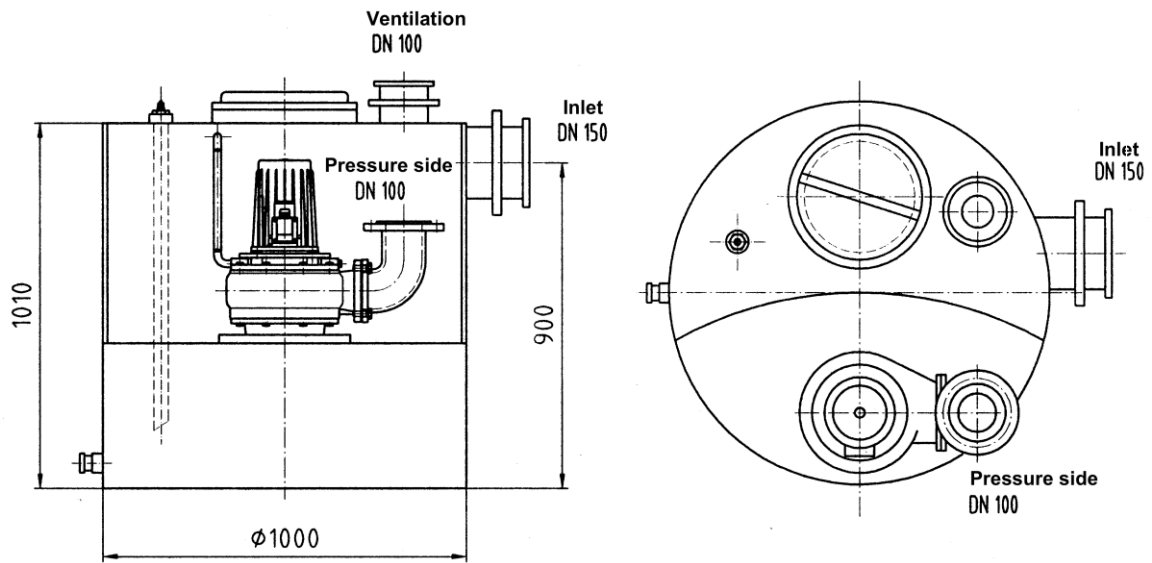

WUZ 100 double

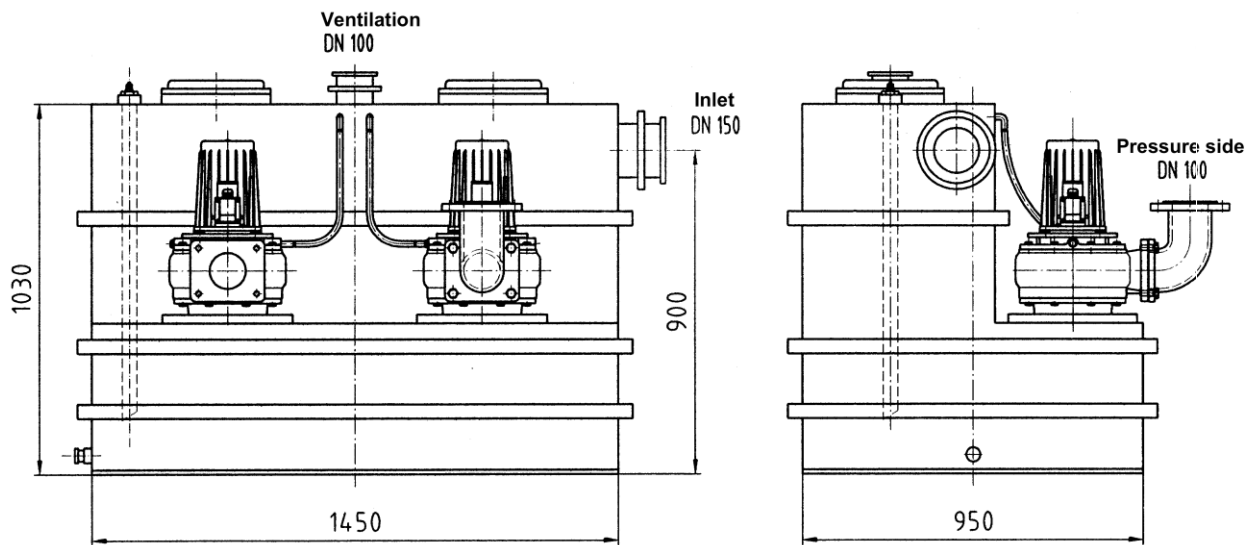

Annex C: Sectional drawing and spare parts list

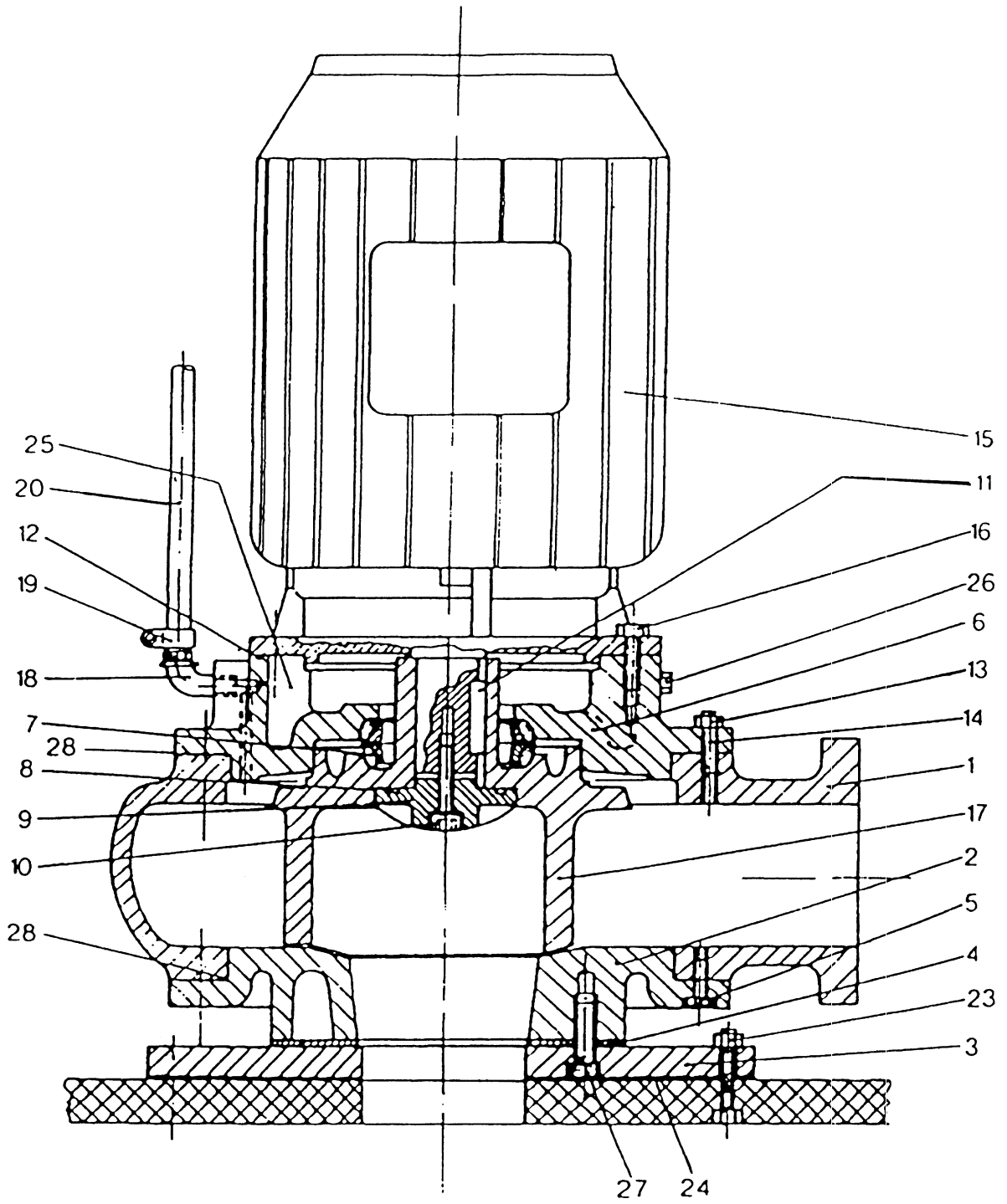

Item	Quantity	Designation	Article No.
1	1 (2)	Pump housing WUZ 100 3.0 and 4.0	ZE1384
	1 (2)	Pump housing WUZ 100 5.5 and 7.5	ZE1138
2	1 (2)	Cover QSHE/101 WUZ 100 3.0 and 4.0	ZE1129
	1 (2)	Cover QSHE/100Z-3 WUZ 100 5.5 and 7.5	120141
3	1 (2)	Reception flange plate	200,005
4	1 (2)	Flat seal 340 x 105 x 3	ZE1566
5	8 (16)	Hexagon screw M10x25	117724
6	1 (2)	Seal carrier GG WUZ 100 3.0 und 4.0	145015
	1 (2)	Seal carrier GG WUZ 100 5.5 und 7.5	145023
7	1 (2)	Mechanical seal 3.0 and 4.0 kW	279950
	1 (2)	Chilled casting seal 5.5 and 7.5 kW	80115
8	1 (2)	O-ring 50 x 3	80114
9	1 (2)	Impeller cap WUZ 100 3.0 and 4.0	120127
	1 (2)	Impeller cap WUZ 100 5.5 and 7.5	120143
10	1 (2)	Hexagon screw M 10 x 30	ZE1237
	1 (2)	Sealing disc Cu 10 x 20 x 2.0 mm	145013
12	1 (2)	O-ring 190 x 3	60107
13	8 (16)	Hexagon screw M 10 x 30 WUZ 100 3.0 and 4.0	ZE1237
	8 (16)	Hexagon screw M 12 x 30 WUZ 100 5.5 and 7.5	ZE1516
15	1 (2)	Motor unit 3.0 kW with impeller	111103
	1 (2)	Motor unit 4.0 kW with impeller	111104
	1 (2)	Motor unit 5.5 kW with impeller	111107
	1 (2)	Motor unit 7.5 kW with impeller	111108
16	4 (8)	Hexagon screw M 12 x 25	ZE1130
	4 (8)	Spring washer B 12	ZE1302
17	1 (2)	Impeller D=200 mm, 3.0 kW	120134c
	1 (2)	Impeller D=220 mm, 4.0 kW	120134e
	1 (2)	Impeller D=230 mm, 5.5 kW	120142a
	1 (2)	Impeller D=250 mm, 7.5 kW	120142b
18	1 (2)	Angle grommet R 3/8"	117031
19	2 (4)	Hose clamp	ZE1582
20	1 (2)	Venting hose	117030
23	8 (16)	Hexagon nut M 12	ZE1382
	8 (16)	Spring washer B 12	ZE1302
24	1 (2)	Flat seal DN 100	ZE1121
25	1 (2)	Oil filling 0.8 l, WUZ 100 3.0 and 4.0	14009
	1 (2)	Oil filling 1.0 l, WUZ 100 5.5 and 7.5	14009
26	1 (2)	Oil filling screw 3/8" thread	140025
26	1 (2)	Seal ring 17 x 22 x 1.5 mm, Cu	140030
27	4 (8)	Hexagon socket screw M 16 x 30	ZE1647
28	1 (2)	O-Ring 236 x 3 WUZ 100 3.0 and 4.0	120131
		O-Ring 270 x 3 WUZ 100 5.5 and 7.5	120139

Switchgears

Quantity	Designation	Article No.
1	Switchgear ZPS1 (3.0/4.0/5.5 kW)	256300
1	Switchgear ZPS1-SD (7.5 kW)	215402
(1)	Switchgear ZPS2 (3.0/4.0/5.5 kW)	255400
(1)	Switchgear ZPS2-SD (7.5 kW)	215403
1 (1)	Small compressor set	71035