

Features:

- complete package for automatic operation of the borehole pump and with additional dry-run protection
- oil-filled asynchronous motor within stainless steel housing with thermal contact
- jacket cooling for continuous duty horizontal / emerged
- sealed with high-grade mechanical seal
- brass bearing shield
- stainless steel pump housing and motor shaft
- modern, powerful pump hydraulics with impellers and guide wheels made of wear-resistant plastic

Application:

- water pumping from deep wells and rainwater cisterns
- domestic water supply, garden irrigation
- agriculture

Scope of delivery:

- pump with 20 m power cable and plug with integrated capacitor, power switch and motor protection
- electronic pressure switch with dry-run protection
- 10 m stainless steel rope with 4 rope clips
- non-return valve



Product benefits:

- complete package for automatic operation
- dry-run protection for additional safety included in the scope of delivery
- jacket cooling for continuous duty horizontal / emerged

Technical data:

Art.no.	U [V]	P ₁ [W]	P ₂ [W]	I _n [A]	n [min-1]	Q _{max} [m ³ /h]	H _{max} [m]	PO	D [mm]	L [mm]	W [mm]	H [mm]	Weight [kg]
11963	230	860	460	3,8	2800	3,1	57,0	G1	78	805	78	78	16,29

Characteristics:

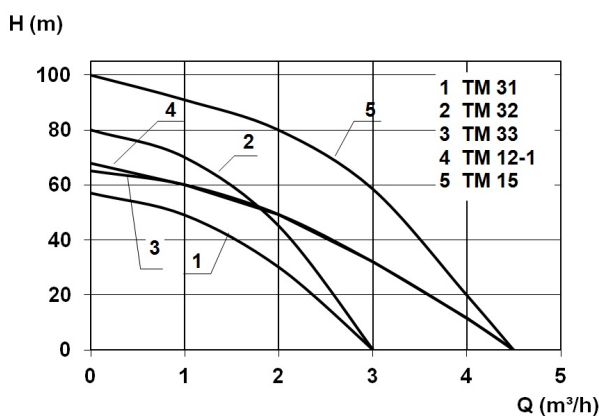

Example of installation:

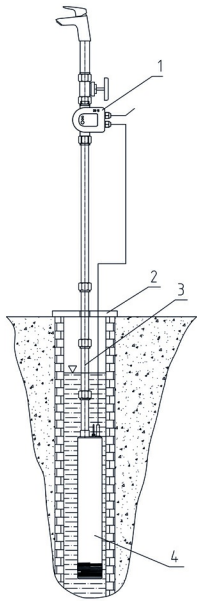

1 pressure switch
2 wellhead
3 pressure pipe
4 pump

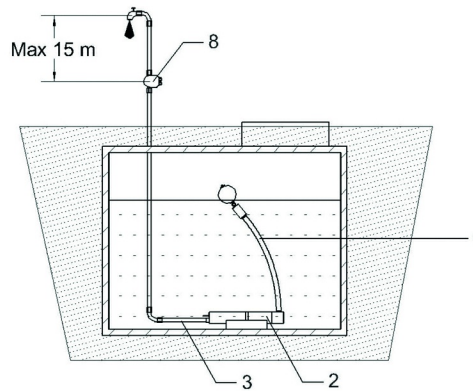

1 floating intake
2 pump with bedding
3 pressure pipe
8 pressure switch with dry-run protection