

**Features:**

- compact and corrosion-resistant sewage water submersible pump
- including floating tap and check valve
- fixed vertical float switch
- with built-in compressor
- connecting cable, 10 m long

**Application:**

- feeder pump for rainwater modules with long suction lines and bigger suction heights
- supply of service water

**Scope of delivery:**

- 10 meter connection cable

**Product benefits:**

- versatile usage
- automatic operation with defined switch points by fixed, vertical float switch
- intake of the cleanest water by supplied floating intake
- LAB-LIP-SEAL system - the motor is protected by three lip seals

**Technical data:**

Art.no.	U [V]	P <sub>1</sub> [W]	I <sub>n</sub> [A]	n [min <sup>-1</sup> ]	Q <sub>max</sub> [m <sup>3</sup> /h]	H <sub>max</sub> [m]	P0	L [mm]	W [mm]	H [mm]	Weight [kg]
19096	230	780	3,5	2850	13,5	11,0	RP1	221	221	285	8

**Characteristics:**

H (m)

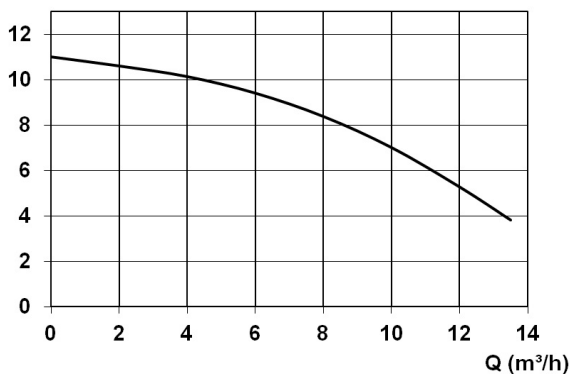
**Materials:**

Material motor housing:

stainless steel AISI 304

**Example of installation:**

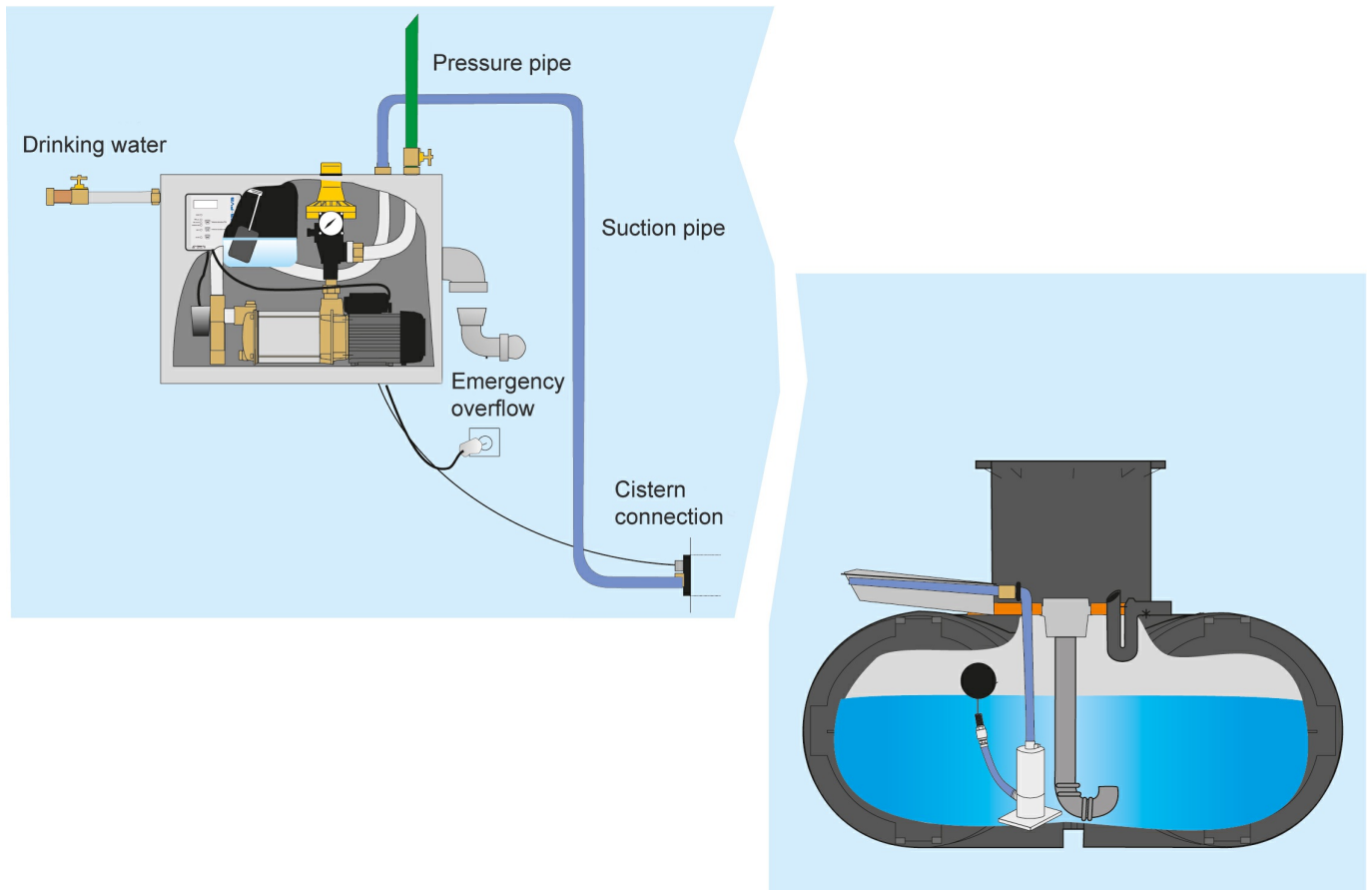

Dimensions:

