

Features:

- self-priming multistage centrifugal pump
- self-priming up to 8 meters
- smoothly running
- max. medium temperature 40 °C
- ready to plug in, 1,5m connection cable

Application:

- water supply for domestic services
- garden irrigation
- washing facilities
- decanting of tanks etc.
- supply of clear water without aggressive and abrasive components

Scope of delivery:

- completely wired including mains cable H07RN-F, with plug

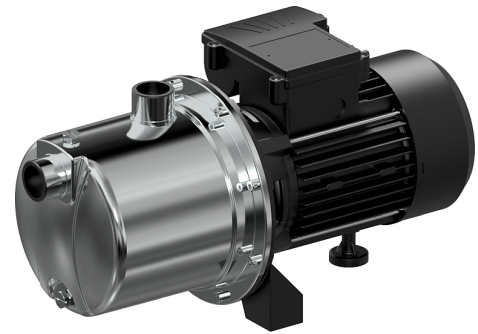
Product benefits:

- smoothly running
- pump housing made of stainless steel
- motor with temperature protection switch
- self-priming up to 8 m

Technical data:

Art.no.	U [V]	P ₁ [W]	P ₂ [W]	I _n [A]	n [min ⁻¹]	Q _{max} [m ³ /h]	H _{max} [m]	P0	L [mm]	W [mm]	H [mm]	Weight [kg]
23034	230	1300	900	5,2	2800	5,0	54,0	RP1	416	200	209	11,5

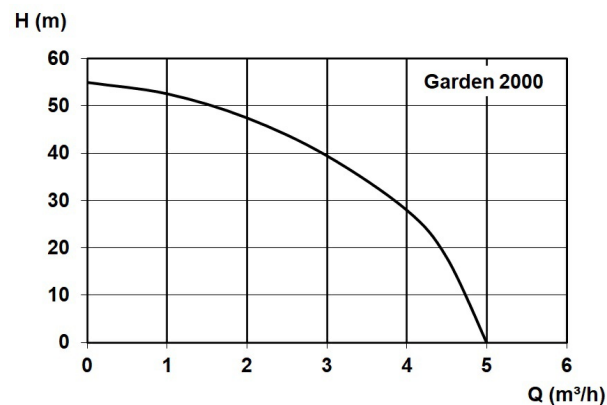
Characteristics:

Materials:

Material impeller:	Noryl
Seal pump:	mechanical seal carbon/ceramic/NBR
Material motor housing:	cast-iron
Material pump housing:	stainless steel AISI 304
Material motor shaft:	stainless steel AISI 304

Dimensions:

