

# GARDEN 1000

## INSTRUCTIONS FOR USE



Processing status: V 4.2 January 2024



For safe and proper use, read the instructions for use and other documents accompanying the product carefully. The instructions for use must be handed over to the end user and kept until the product is disposed of.

You have purchased a high-quality product and we congratulate you on your decision. The product was checked for proper condition before delivery as part of the quality controls. To ensure that you enjoy the product for a long time, please read and follow these instructions for use.

The following guidance will make it easier for you to use the instructions for use:



Useful tips and additional information to make your work easier



Step-by-step instructions



References to further information in these instructions for use.



Indicates a dangerous situation that can lead to material damage.



Warning of a hazard that could lead to personal injury.



Warning of dangerous electrical voltage.



We are constantly working on the further development of all our products. We therefore reserve the right to make changes to the scope of delivery in terms of form, technology and equipment.

No claims can therefore be derived from the information and illustrations in these instructions for use.

**Table of contents**

<b>1</b>	<b>General information .....</b>	<b>4</b>
	1.1 Introduction.....	4
	1.2 Warranty.....	4
<b>2</b>	<b>Security.....</b>	<b>5</b>
	2.1 Symbols in these instructions for use .....	5
	2.2 Intended use.....	6
	2.3 Selection and qualification of persons .....	7
	2.4 Personal protective equipment .....	8
	2.5 Basic hazard potential .....	9
	2.6 Unauthorized conversion and manufacture of spare parts .....	9
	2.7 Dangers if the safety instructions are not observed.....	10
	2.8 Safety-conscious working .....	10
	2.9 Responsibility of the operator/owner .....	10
<b>3</b>	<b>Transportation and storage.....</b>	<b>11</b>
	3.1 Transportation .....	11
	3.2 Interim storage/preservation .....	11
<b>4</b>	<b>Product description .....</b>	<b>12</b>
	4.1 Scope of delivery .....	12
	4.2 Application example.....	13
<b>5</b>	<b>Assembly.....</b>	<b>14</b>
	5.1 Preparations .....	14
	5.2 Suction line.....	16
	5.3 Pressure line.....	17
<b>6</b>	<b>Initial commissioning and operation .....</b>	<b>18</b>
	6.1 System handed over to the user.....	19
	6.2 Operation.....	19
<b>7</b>	<b>Maintenance and servicing .....</b>	<b>20</b>
<b>8</b>	<b>Detecting and rectifying faults .....</b>	<b>21</b>
<b>9</b>	<b>Technical data .....</b>	<b>22</b>
	9.4 Nameplate .....	24
<b>10</b>	<b>Spare parts lists .....</b>	<b>25</b>
<b>11</b>	<b>Environmental information.....</b>	<b>28</b>
<b>12</b>	<b>Declaration of Conformity .....</b>	<b>28</b>

## 1 General information

### 1.1 Introduction



These operating instructions are valid for the GARDEN 1000 pump. These operating instructions enable safe handling of the pump. The operating instructions are an integral part of the pump and must be kept in the immediate vicinity of the pump, accessible to personnel at all times.

If you have any questions about the GARDEN 1000 pump and these operating instructions, please contact:

Zehnder Pumpen GmbH  
Zwönitzer Straße 19  
08344 Grünhain-Beierfeld  
Phone: +49 (0) 3774 / 52-100  
Fax: -150  
info@zehnder-pumpen.de

### 1.2 Warranty

In principle, the statutory warranty regulations apply.

Within this warranty period, we shall, at our discretion, remedy all defects attributable to material or manufacturing defects by repair or replacement free of charge.

Damage caused by improper use and wear and tear is excluded from the warranty. Consequential damage caused by failure of the appliance is not covered by us.

A copy of the proof of purchase and proof of proper initial commissioning are required for warranty registration.

Failure to observe the operating instructions - in particular the safety instructions - as well as unauthorized modification of the appliance or the installation of non-original spare parts automatically voids the warranty. The manufacturer accepts no liability for any resulting damage!



In the event of defects or damage, please contact your dealer first. He is always your first point of contact!





## 2 Security



These instructions for use contain basic information that must be observed during installation, operation and maintenance. It is therefore essential that these operating instructions are read by the installer and the responsible specialist personnel/operator before installation and commissioning and must be available at the installation site at all times. Not only the general safety instructions listed under this main point Security must be observed, but also the other special safety instructions listed.

### 2.1 Symbols in these User Manual

Safety instructions are labelled with symbols in these operating instructions.

Warning sign and signal word		Meaning	
	<b>DANGER</b>	<b>Personal injury</b>	Indicates a hazardous situation which, if not avoided, will result in death or serious injury.
	<b>WARNING</b>		Indicates a hazardous situation which, if not avoided, could result in death or serious injury.
	<b>CAUTION</b>		Indicates a hazardous situation which, if not avoided, may result in moderate or minor injury.
	<b>DANGER</b>		All live components are protected against accidental contact. Before opening housing covers, plugs and cables, they must be de-energized. Work on electrical components may only be carried out by qualified personnel.
	<b>ATTENTION</b>	<b>Material damage</b>	Indicates a situation which, if not avoided, may result in damage to components, the system and/or its functions or an object in its vicinity.



Furthermore, they must be observed and kept in a completely legible condition:

- Instructions attached directly to the machine, such as the direction of rotation arrow.
- The marking of the fluid connections.



Observing the following instructions will ensure trouble-free operation.

Non-observance can lead to failure of the electronics, malfunctions and shortened service life. The operator bears the responsibility.

## 2.2 Intended use

The GARDEN 1000 is an extremely smooth-running self-priming electric centrifugal pump with built-in injector, for suction heights up to max. 8 m, for the following applications:

- Water pumping in building services
- Garden irrigation
- Smaller irrigation systems
- Refilling tanks etc

The pump can be used for commercial or non-commercial purposes. Only clear to slightly contaminated water without aggressive and abrasive components may be used as the pumped medium.

Sand and other abrasive solids lead to heavy wear; any resulting damage is excluded from the warranty.

The domestic waterworks are approved for operation:

- with 230 Volt 50 Hertz alternating voltage
- up to a water temperature of 40 °C

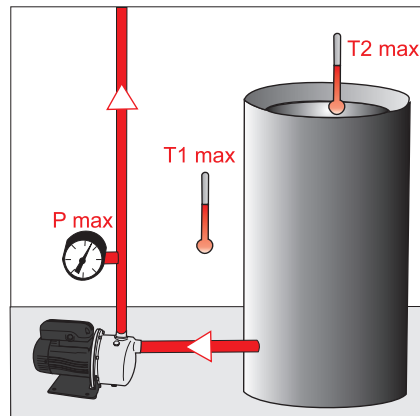
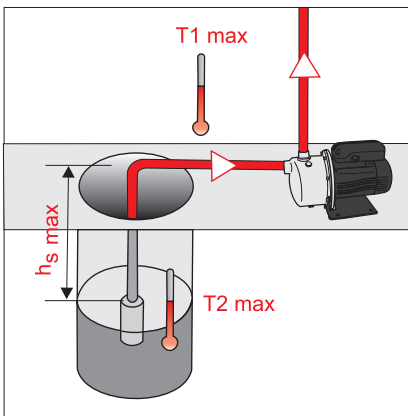

Typ	T1 max C°	T2 max C°	P max bar	$h_s$ max [m]
GARDEN 1000	40	40	8	8



Use on swimming pools, garden ponds and their protected areas is only permitted if these are installed in accordance with VDE 0100/49 D. The domestic waterworks must not be placed in water or submerged.

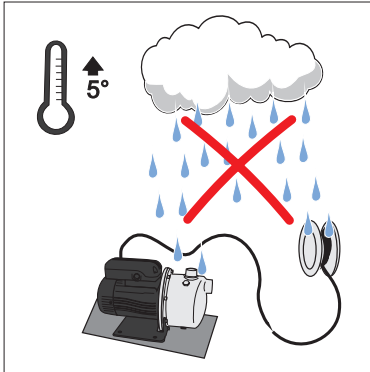

The following fluids are not suitable

- Corrosive, flammable and explosive media
- Waste water, e.g. from urinals and toilets

### 2.3 Selection and qualification of persons

All work on the pump must be carried out by qualified personnel if the activities are not expressly designated for other persons (owner, user) in these operating instructions.

Specialists are persons who, through their training and experience, are familiar with the relevant regulations, applicable standards and accident prevention regulations. They can recognize and avoid potential hazards. The personnel for operation, maintenance, inspection and installation must have the appropriate qualifications for this work.

Work on electrical components may only be carried out by trained specialist personnel in compliance with all applicable accident prevention regulations.





The operator/owner must ensure that only qualified personnel work on the system. Furthermore, the operator/owner must ensure that the contents of the operating instructions are fully understood by the personnel.

This appliance can be used by persons with reduced physical, sensory or mental capabilities or lack of experience and knowledge if they have been given supervision or instruction concerning use of the appliance in a safe way and understand the hazards involved. This appliance must not be used by children. Children must not play with the appliance. Cleaning and user maintenance must not be carried out by children.

## 2.4 Personal protective equipment

Personal protective equipment may be required for various activities on the system. Personal protective equipment must be made available to personnel and its use must be monitored by supervisors.

If protective equipment must be used, this is indicated by the following symbols:

Commandment sign	Meaning	Explanation
	Wear safety shoes	Safety shoes offer good slip resistance, especially in wet conditions, as well as high penetration resistance, e.g. for nails, and protect feet from falling objects, e.g. during transportation
	Wear a safety helmet	Safety helmets protect against head injuries, e.g. from falling objects or impacts
	Wear protective hand shoes	Protective gloves protect hands from minor bruising, cuts, infections and hot surfaces, especially during transportation, commissioning, maintenance, repair and dismantling.
	Wear protective clothing	Protective clothing protects the skin from light mechanical influences and infections in the event of wastewater leaks
	Wear safety goggles	Safety goggles protect the eyes in the event of waste water leaks, especially during commissioning, maintenance, repair and decommissioning

## 2.5 Fundamental Hazard potential



If hot or cold machine parts lead to hazards, these parts must be secured against contact on site.



Contact protection for moving parts (e.g. coupling) must not be removed when the system is in operation.



Leaks (e.g. of the shaft seal) of hazardous conveyed goods (e.g. explosive, toxic, hot) must be discharged in such a way that there is no danger to persons or the environment. Legal regulations must be complied with.



Hazards due to electrical energy must be excluded (details can be found in the country-specific regulations and the regulations of the local power supply companies).

Work on the machine should only be carried out when it is at a standstill. The procedure described in the operating instructions for shutting down the machine must be strictly adhered to.

Contact with waste water or contaminated pump parts, e.g. when clearing blockages, can lead to infections. Protective equipment must be worn.

↳ Section 2.4 "Personal protective equipment"

Pumps or pump units that convey media that are hazardous to health must be decontaminated.

Immediately after completing the work, all safety and protective devices must be refitted and/or put back into operation, e.g. the contact protection for the clutch and the fan wheel.

Before (re)commissioning, the points listed in the section Initial commissioning must be observed.

## 2.6 Unauthorized conversion and spare parts production

The system has undergone extensive quality controls up to its market launch and all components have been tested under the highest loads. The installation of non-approved parts impairs safety and invalidates the warranty. Only original parts or spare parts approved by the manufacturer should be used for replacement.

## 2.7 Dangers if the safety instructions are not observed



Failure to observe the safety instructions may result in danger to persons, the environment and the machine. Failure to observe the safety instructions may result in the loss of any claims for damages.

Failure to observe the safety instructions can result in the following hazards, for example:

- Failure of important functions of the machine / system
- Failure of prescribed methods for maintenance and servicing
- Danger to persons due to electrical, mechanical and chemical effects
- Danger to the environment due to leakage of hazardous substances

## 2.8 Safety-conscious Working

In addition to the safety instructions listed in these operating instructions, the accident prevention regulations and any internal work, operating and safety regulations of the operator/owner must also be observed.

## 2.9 Responsibility of the operator / owner

Compliance with the following points is the responsibility of the operator/owner:

- The system may only be operated as intended in the proper condition.
  - ↪ Chapter 2.2 "Intended use"
- The function of the protective devices, e.g. contact protection of the clutch and fan wheel, must not be impaired.
- Maintenance intervals must be observed and faults must be rectified immediately. Only rectify faults yourself if the measures are described in these operating instructions. Specialists are responsible for all other measures - if necessary, contact the factory customer service.
- The type plate of the system must be checked for completeness and legibility.
  - ↪ Section 9.1 "Nameplate"
- A sufficient amount of personal protective equipment must be available and worn.
  - ↪ Section 2.4 "Personal protective equipment"
- The operating instructions must be legible and complete and made available at the place of use.
- Only qualified and authorized personnel may be deployed.
  - ↪ Section 2.3 "Selection and qualification of persons"

### 3 Transportation and Storage

#### 3.1 Transportation

During transportation, ensure that the system is not knocked or dropped.

#### 3.2 Interim storage/preservation

When decommissioning, the water from the domestic waterworks must be completely drained. For temporary storage and preservation, it is sufficient to store it in a cool, dark and frost-proof place. The control unit must be protected against moisture.

For long-term storage (longer than 3 months), all bare metal parts that are not made of stainless steel must be treated with a preservative. The preservation must then be checked every 3 months and renewed if necessary.

After prolonged storage of pumps, they must be checked before they are put into operation (again). To do this, check that the shaft can move freely by turning it by hand.

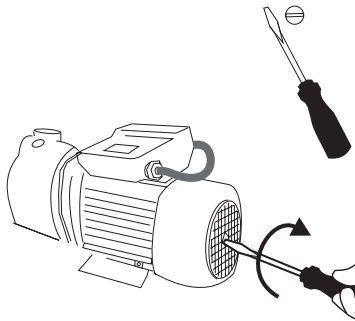

## **4 Product description**

The GARDEN 1000 is a self-priming, smooth-running, horizontal electric centrifugal pump with built-in injector, for suction heights up to max. 9 m.

The pump must be installed in a dry and flood-proof location.

The suction line must be vacuum-proof and end at least 25 cm below the water level. This prevents the formation of vortices and the inevitable ingress of air.

The pipe connections must be 100% airtight. The suction line should have a minimum gradient of 2% over its entire length. The diameter of the suction line must be equal to or larger than the suction nozzle.

A pipe diameter should be selected for the pressure line that is as close as possible to the inside diameter of the pump's discharge nozzle.

### **4.1 Scope of delivery**

GARDEN 1000

- Electrically wired Cable type H05 RN-F 1.5 m
- ready to plug in
- with on/off switch

## 4.2 Application example

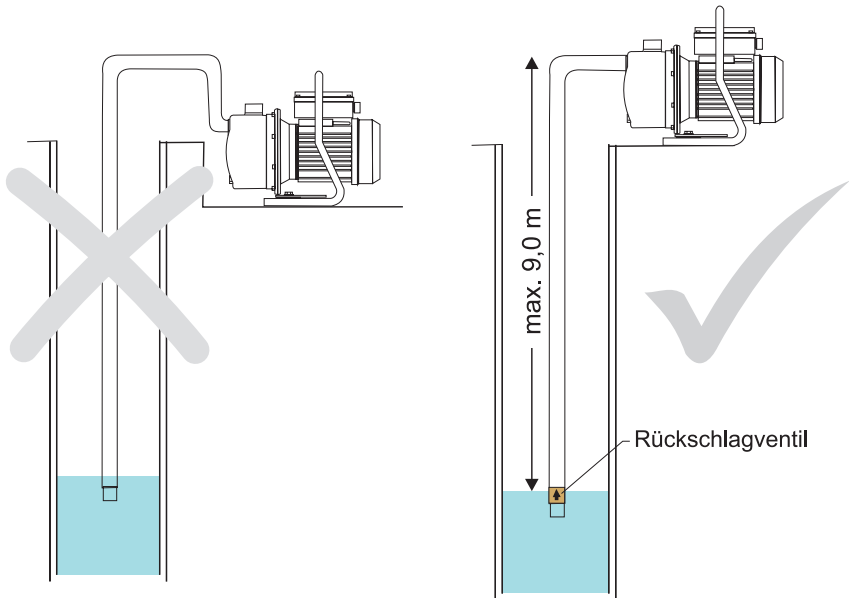

!

The suction point must be selected so that the pump is always supplied with clear, uncontaminated water. A filter (suction strainer) can be used to protect the pump. The mesh size should not be too fine. In practice, mesh sizes of 1 - 3 mm have proven to be good. If a filter with a smaller mesh size is required for special applications, it should preferably be installed on the pressure side. Filter systems must be regularly maintained (cleaned). Non-maintained filter systems can damage the pump.

If the pump is to pump from an unpressurized container (e.g. cistern) or a body of water, a foot valve must be fitted on the suction side.

## 5 Assembly

### 5.1 Preparations

Check that the system is suitable for the mains supply (230 V/50 Hz) as specified on the packaging. Ensure that all safety regulations are complied with. Check that the pumped medium corresponds to the media listed in section 2.2.

1. Remove the domestic waterworks from the packaging.
2. Check for perfect external condition (transport damage).

#### Safety regulations

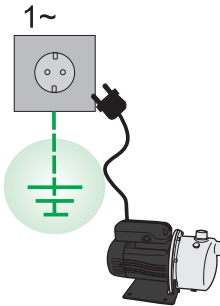

The pump must be connected to a socket outlet with earthing (mandatory provision in accordance with DIN VDE 100)

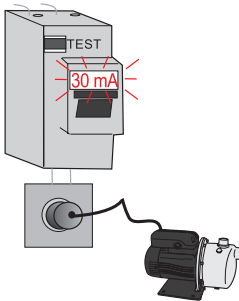

If the power supply does not have to be provided via an RCD with max. 30 mA rated residual current, the pump must be connected via a separate RCD in the socket (mandatory regulation EN 60 335-2)

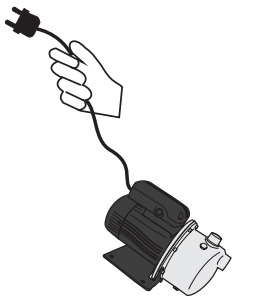

Do not pull or carry the pump by the cable

## Safety regulations

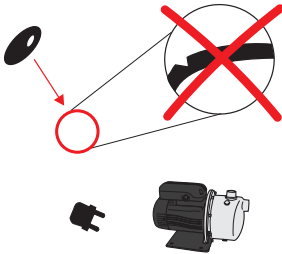

The pump must not be put into operation with a damaged cable

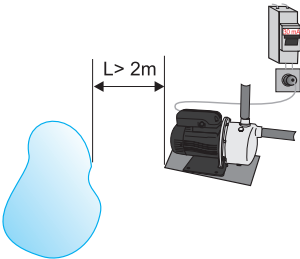

The pump must not fall into the water and must be protected against flooding

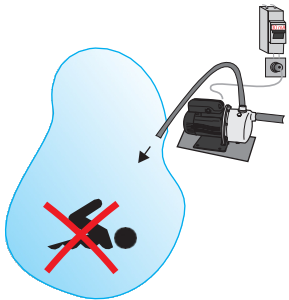

The pump may only be used in swimming pools and garden ponds if the systems are installed in accordance with DIN VDE 0100 Part 702. Do not bathe in the pool when the pump is in operation

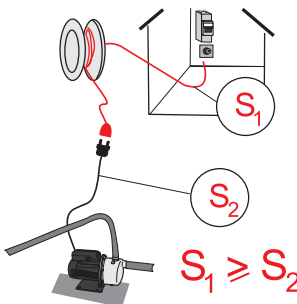

Extension cables must have at least the same cross-section as the pump connection cable

$S$  (mm<sup>2</sup>)

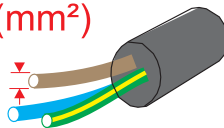

## 5.2 Connecting the Suction line

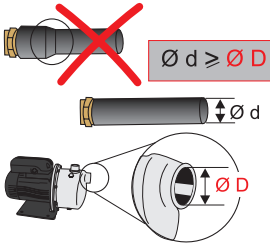
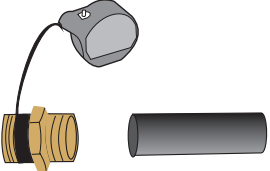
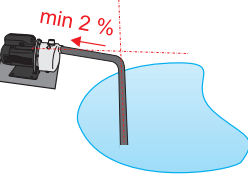
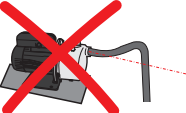
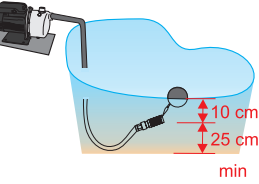
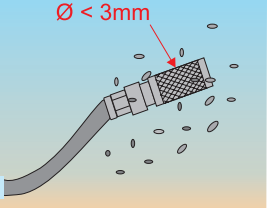
Connecting the suction line	
	<ul style="list-style-type: none"> <li>• The suction line must be made of material that is resistant to negative pressure</li> <li>• The inside diameter of the suction line must be at least as large as the inside diameter of the suction nozzle</li> </ul>
	<ul style="list-style-type: none"> <li>• The suction line connection on the pump should preferably be sealed with thread sealant Teflon tape can be used as an alternative</li> </ul>
	<ul style="list-style-type: none"> <li>• The suction line must be laid continuously rising towards the pump</li> </ul> 
	<ul style="list-style-type: none"> <li>• The suction point must be selected so that the pump is always supplied with clear, uncontaminated water</li> <li>• It must be ensured that the suction is always in the water and that no bottom sediments are sucked in</li> </ul>
	<ul style="list-style-type: none"> <li>• A strainer with a maximum passage of 3 mm must be used at the end of the suction line</li> <li>• There should be a non-return valve (e.g. a spring-loaded non-return valve) directly on the strainer</li> </ul>

- ! Do not install any additional fine filters, water meters etc. in the suction line of the pump! These components are unnecessary flow resistors; with fine filters in particular, there is a risk that they will become clogged and cause damage to the pump.

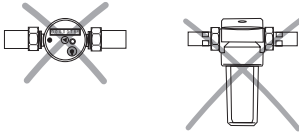



The strainer at the suction (preferably floating extraction) is sufficient to protect the pump!

If a fine filter is required, it may be installed in the pressure line. A backwashable fine filter should even be used here. This makes it easier to clean the filter regularly.

- ! Dirt can get into the suction line when laying the suction line! If this cannot be ruled out, the suction line must be flushed before connecting it to the basic unit.

### 5.3 Connecting the Pressure line

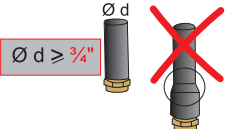
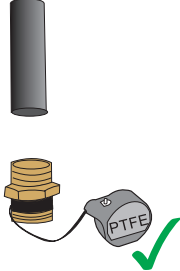
#### Connecting the pressure line



	<ul style="list-style-type: none"> <li>• The pressure outlet of the garden pump has a 1" internal thread</li> <li>• The inside diameter of the pressure line must be at least 3/4"</li> </ul>
	<ul style="list-style-type: none"> <li>• The pressure line connection on the pump should preferably be sealed with thread sealant, preferably PTFE thread, e.g. Loctite 55</li> </ul>  <p>No Teflon</p>

- ! The pressure connection must always be held against when tightening! It is recommended to provide a shut-off valve on the pressure side for maintenance and service purposes!

## 6 Initial commissioning and operation

- !** Before commissioning, all connections must be checked again for correct installation. In particular, check that the voltage and frequency of the power supply and garden pump match (see type plate). It must be ensured that the safety regulations are complied with. Commissioning may only be carried out by authorised specialist personnel.

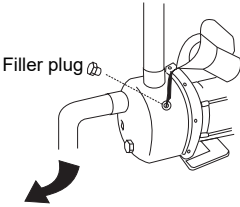
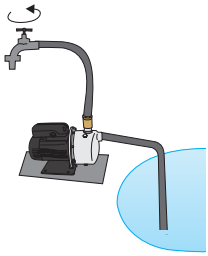
The garden pump is a horizontal electric centrifugal pump with a built-in injector. The suction line must be absolutely tight to ensure self-priming.

Commissioning	
 <p>Filler plug</p>	<ul style="list-style-type: none"> <li>• Fill the pump body and the suction line with water by screwing on the filler plug and close the filler openings again</li> <li>• <b>Never operate the pump dry</b></li> </ul>
	<ul style="list-style-type: none"> <li>• Open all existing shut-off valves (suction and pressure line)</li> <li>• Open consumer</li> </ul>
	<ul style="list-style-type: none"> <li>• Insert the pump plug into the socket</li> <li>• Switch on the pump</li> </ul>

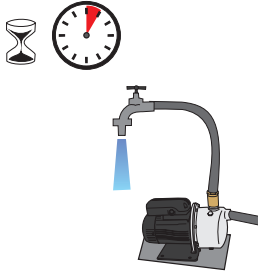
**Commissioning**

- If the pump has been running for 3 minutes without malfunction - the pump can be switched off and the consumers can be switched off

Depending on the height of the suction pipe, the priming time can be up to 5 minutes. If the pump does not deliver, it must be primed again. If the pump still does not pump, it must be assumed that:

- the suction seal is leaking (draws air),
- the suction strainer is clogged,
- the suction hose is kinked,
- the maximum suction height is exceeded.

### 6.1 System handed over to the user

On handover to the user:

- Explain how the system works.
- System handed over in working order.
- Hand over the handover protocol with key commissioning data (e.g. changes to the factory settings).
- Hand over instructions for use.

### 6.2 Operation



The system may only be operated as intended  Chap. 2.2 "Intended use"



The system works automatically. In addition to regular maintenance, only regular visual inspections should be carried out. In the event of irregularities, expert personnel must be consulted, e.g. customer service partners authorized by the manufacturer.

## 7 Maintenance and Maintenance



For repair and maintenance work on the control unit and/or pump, always disconnect the mains plug from the socket; it must be secured against being plugged back in.

The pump should be checked regularly to ensure that it is working properly and running smoothly. This can prevent major malfunctions.

Dry running of the pump must be avoided as the mechanical seal is cooled by the liquid. The motor is maintenance-free. If there is a risk of frost, drain the pump using the drain plug.

The pump should be drained during the cold season and if it is not used for a longer period of time. If the pump is not used at all for a longer period of time, it should be cleaned and stored in a dry, well-ventilated place.

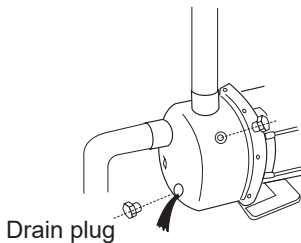

## 8 Recognizing and Lifting faults

Malfunction	Cause	Remedy
Pump does not start	<ul style="list-style-type: none"> <li>• Mains voltage missing</li> <li>• Pump impeller blocked Thermal monitor has therefore switched off the motor</li> </ul>	<ul style="list-style-type: none"> <li>• Check whether the mains plug is in the socket</li> <li>• Dismantle and clean the pump section It is essential to pull out the mains plug</li> </ul>
Pump does not prime	<ul style="list-style-type: none"> <li>• Suction valve not in the water</li> <li>• Pump impeller without water</li>   <li>• Air in suction line</li> <li>• Foot valve blocked</li> <li>• Max. suction height exceeded</li> </ul>	<ul style="list-style-type: none"> <li>• Attach suction line under water</li> <li>• Fill pump with water Fill the suction hose if necessary</li>   <li>• Check the tightness of the suction line</li> <li>• Cleaning the foot valve</li> <li>• Check the suction height, change the location of the pump if necessary (closer to the water level)</li> </ul>
Insufficient flow rate	<ul style="list-style-type: none"> <li>• Suction height too high</li> <li>• Suction strainer dirty</li> <li>• Water level drops</li> <li>• Pump performance reduced due to contamination</li> </ul>	<ul style="list-style-type: none"> <li>• Check suction height, change location if necessary</li> <li>• Cleaning the suction strainer</li> <li>• Lower the suction valve</li> <li>• Dismantle and clean the pump, replace wearing parts if necessary</li> </ul>
Thermal switch switches off the pump	<ul style="list-style-type: none"> <li>• Motor overloaded as friction is too high due to dirt in the pump housing</li> </ul>	<ul style="list-style-type: none"> <li>• Dismantle and clean pump, reduce suction of foreign matter</li> </ul>
Thermal switch switches the pump off after a brief motor hum	<ul style="list-style-type: none"> <li>• Capacitor defective</li> </ul>	<ul style="list-style-type: none"> <li>• Replace capacitor (call in a qualified electrician) Customer service</li> </ul>

## 9 Technical data

GARDEN 1000	
Frequency	50 Hz
max. medium temperature	40° C
Max. operating temperature	40° C
Max. operating pressure	8 bar
Nominal operating mode	S2 90 min
Protection class	IP 55
Pressure connection	1" INTERNAL THREAD
Suction connection	1" INTERNAL THREAD

Type	Rated current [A] 1~ 230 V	Motor power P <sub>1</sub> [kW] 1~	max. Delivery head [m]	max. Flow rate [m <sup>3</sup> /h]	Weight [kg]
GARDEN 1000	5,2	1,0	50	3,6	11,8

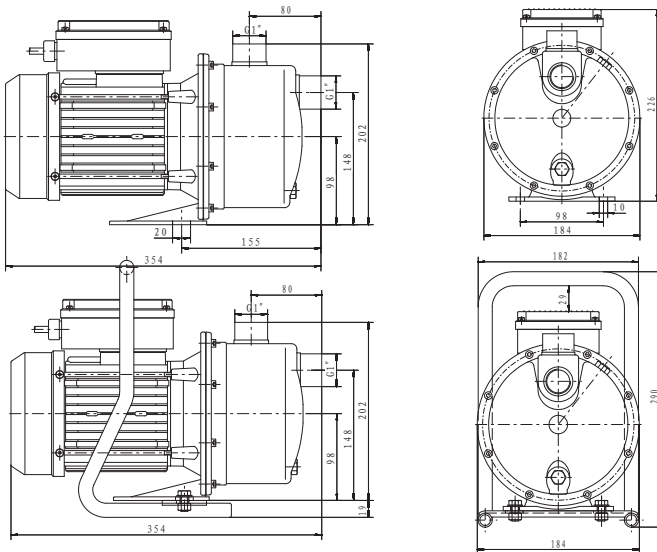

## Material

- Pump housing, seal housing and impeller made of stainless steel 1.4301
- Shaft end made of stainless steel 1.4401
- Diffuser and injector made of thermoplastic material (suitable for drinking water)
- Mechanical seal made of carbon / ceramic / NBR
- Stainless steel filling/draining screw

**Power connection in the terminal box**

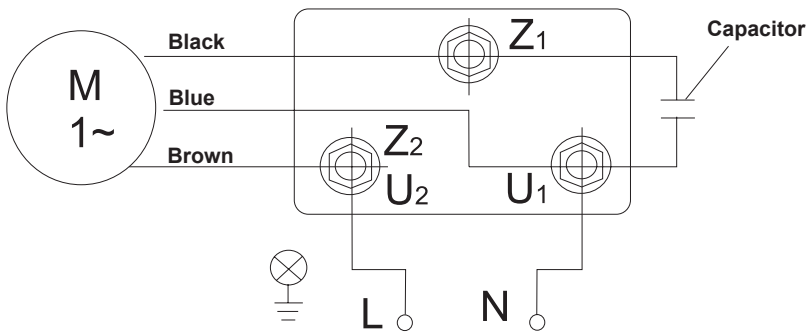
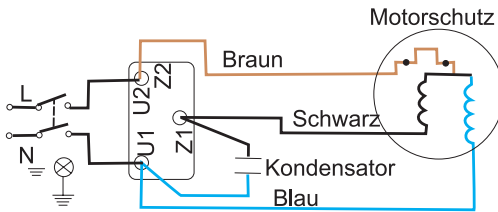
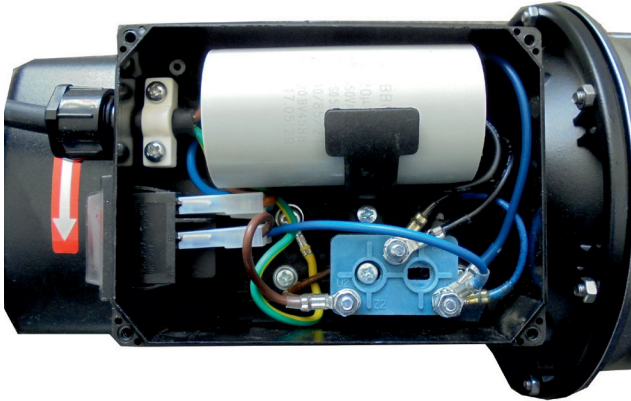

### Characteristic curve

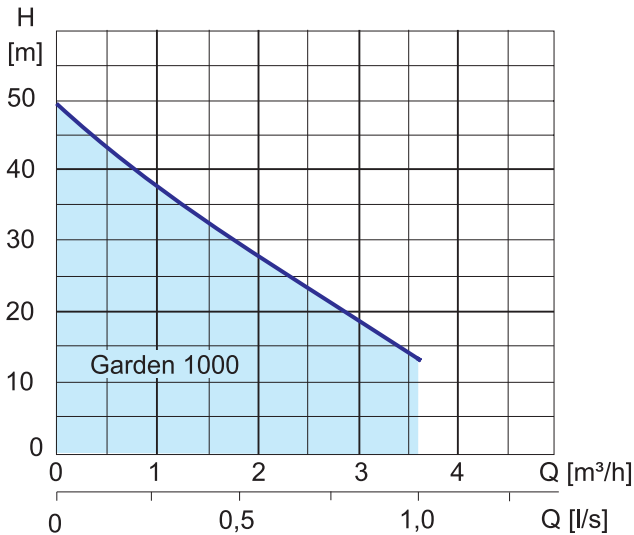

### 9.1 Type plate

A type plate is attached to the pump, which contains all the important technical information.



**zehnder**  
 PUMPEN

 Zehnder Pumpen GmbH  
 Zwönitzer Straße 19  
 08344 Grünhain-Beierfeld  
 www.zehnder-pumpen.de

## Garden 1000 M 230 V

$P_1$ : 1000 W	S/N : xxxxxx
U,f : 230 V, 50 Hz	$Q_{max}$ : 3,6 m³/h
$I_N$ : 5,2 A	$H_{max}$ : 50 m
n : 2900 U/min	$t_{max}$ : 40°C
C : 20 µF	S2 90 min IP 55

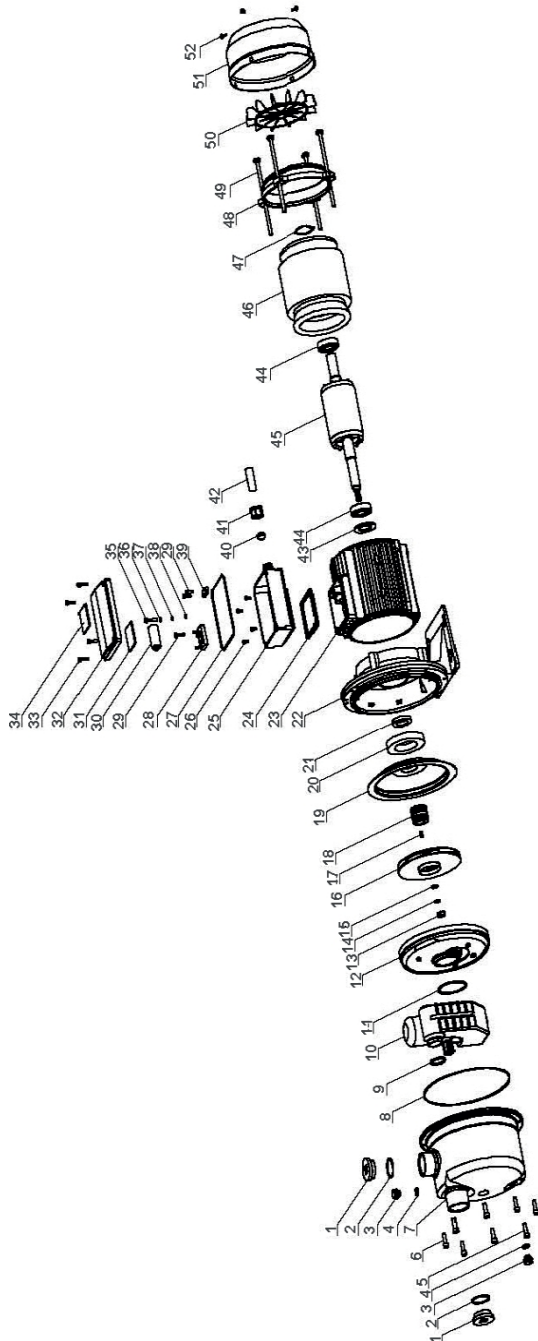

**10. spare parts list**

Part	Quantity	Garden 1000	Material	Zehnder factory number
1	2	Suction and discharge nozzle cap	PP	19858
2	2	Dust seal	NBR	19859
3	2	Filler/drain plug M 10 x 1.25	AISI 304	19143
4	2	O-ring filler plug	NBR	19861
5	6	Hexagon head screw M 5 x 10	AISI 304	19862
6	2	Hexagon head screw M 5 x 18	AISI 304	19863
7	1	Pump housing	AISI 304	19201
8	1	Housing O-ring D 160 x 4.5	NBR	19147
9	1	O-ring ejector small D 30 x 3.1	NBR	19197
10	1	Injector	PPO	19155
11	1	Guide wheel seal	NBR	19140
12	1	Guide wheel	PPO	19177
13	1	Nut M8	AISI 304	19870
14	1	Spring washer	AISI 304	19871
15	1	Washer	AISI 304	19872
16	1	Impelle	AISI 304	19174
17	1	Bolt C 4 x 12	AISI 304	19874
18	1	Mechanical seal	Carbon/ceramic/NBR	19152
19	1	Pressure plate	AISI 304	19142
20	1	Sealing ring	NBR	19840
21	1	Sealing ring rear panel	Rubber	19841
22	1	Back panel	ADC 3	19203
23	1	Motor housing		198883
24	1	Bottom terminal box seal	NBR	19884
25	1	Terminal box Housing base	flame resistant ABS	19885
26	4	M 4 x 8 screw	galvanized	19886

Part	Quantity	Garden 1000	Material	Zehnder factory number
27	1	Top terminal box seal D120x2	NBR	19887
28	1	Clipboard	Melamine	19888
29	3	Screw ST 3.5 x 13	galvanized	19889
30	1	Capacitor $\mu$ F 20 450 V		16890
31	1	Connection diagram	Stickers	19891
32	1	Terminal box cover	flame resistant ABS	19892
33	4	Screw ST 3.5 x 16	galvanized	19893
34	1	Type plate		19894
35	1	M 5 x 10 screw	AISI 304	19895
36	1	Spring washer	AISI 304	19896
37	1	Pad	AISI 304	19897
38	1	Pad	AISI 304	19898
39	1	Bracket	flame resistant ABS	19899
40	1	Cable entry seal	NBR	19900
41	1	Cable gland	flame resistant ABS	19901
42	1	Cables		19902
43	1	Gasket	NBR	19842
44	2	Ball bearing 6202-2RS		13151
45	1	Rotor		19905
46	1	Stator		19906
47	1	Spring washer		19907
48	1	Bearing cap	ADC 3	19169
49	4	Threaded rods	galvanized	19909
50	1	Fan wheel	PP	19189
51	1	Fan cover	08F	19185
52	1	M 4 x 8 screw	AISI 304	19912

## 11 Environmental information

The cardboard packaging is recyclable and should be disposed of with waste paper. Please dispose of the polystyrene padding via the dual system (yellow bag).

Old electrical and electronic appliances often contain materials that can be reused. However, they also contain harmful substances that were necessary for the function and safety of the appliance. In residual waste or if handled incorrectly, these substances can be harmful to human health and the environment. Therefore, never dispose of your old appliance in the residual waste!

Use the municipal collection points set up at your place of residence to return and recycle defective electrical or electronic devices.



## 12 Declaration of conformity

We hereby declare that the appliance described below complies with the relevant essential requirements of the following directives due to its design and construction:

- |                                 |            |
|---------------------------------|------------|
| • Machinery Directive           | 2006/42/EC |
| • Low Voltage Directive         | 2014/35/EU |
| • Electromagnetic compatibility | 2014/30/EU |
| • RoHS Directive                | 2011/65/EU |

Product designation: **GARDEN**

Type designation: **1000**

Applied EN standards: EN-60730-2-6, EN-60730-1, EN-61000-6-1, EN-61000-6-3, IEC-60730-1, IEC-60730-2-6

The installation and operating instructions must be observed and followed.

**ZEHNDER Pumpen GmbH**  
**Zwönitzer Straße 19**  
**08344 Grünhain-Beierfeld**

Grünhain, the 25.06.2024



Alexander Duba  
Produktmanager