

Features:

- seamless plastic container made from one piece
- all installation parts made of plastic
- low maintenance costs due to easy to clean inner surface
- car- and/or truck-accessible

Application:

- waste water treatment in catering and meat processing companies

Scope of delivery:

- tank with piping
- manhole cover (car or truck bearing)
- sampling shaft
- teleskop-Domschacht – Telescopic dome shaft



Product benefits:

- no odour nuisance in the building
- space-saving

Technical data:

Art.no.

23698

Dimensions:

Type: NS 2 / NS 4

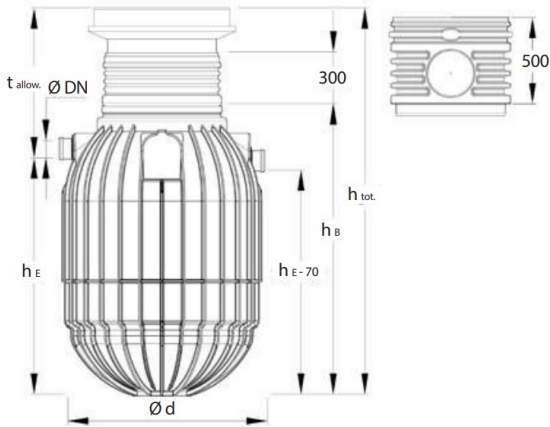

Type: NS 7 / NS 10 / NS 15

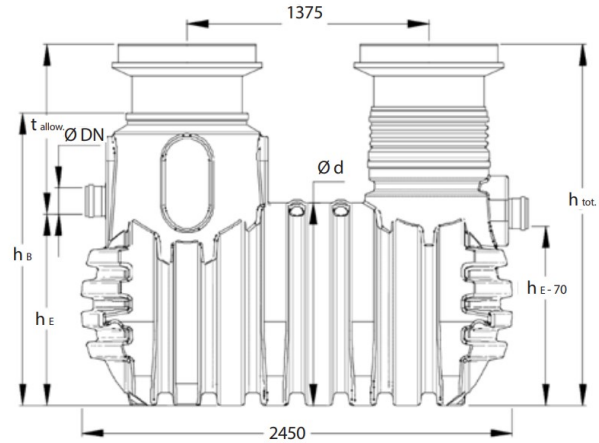

Grease separators		NS 2-200-2	NS 4-500	NS 7-700	NS 10-1500	NS 15-1500
Connection $\varnothing DN$		110	110	160	200	200
H_E (mm)		820	1350	1080	1280	1280
Cover class. B*	t_{allow} (mm)	800-980	870-1050	880-1060	930-1110	930-1110
	h_{tot} (mm)	1620-1800	2220-2400	1960-2140	2210-2390	2210-2390
Cover class. D*	t_{allow} (mm)	830-1010	910-1090	920-1100	970-1150	970-1150
	h_{tot} (mm)	1650-1830	2260-2440	2000-2180	2250-2430	2250-2430
Container	$\varnothing d$ (mm)	1160	1160	1150	1400	1400
	h_B (mm)	1030	1650	1655	1905	1905
	Weight (kg)	41.0	100.0	165.0	250.0	250.0

* When using the 500 mm intermediate piece, the installation depths increase by 200 mm.